



Math Virtual Learning

Grade 7 /Surface Area of Cubes and Rectangular Prisms

May 12, 2020



Grade 7/Surface Area of Cubes and Rectangular Prisms

Lesson: May 12, 2020

Objective/Learning Target:
Find surface area of cubes and rectangular prisms.

Let's Get Started:
Watch Video: [Surface Area](#)

Vocabulary:

Area is the size of a surface or face.
(length x width)

Example: What is the area of this rectangle?

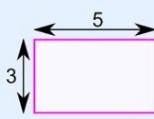

The formula is:

$$\text{Area} = w \times h$$

w = width
h = height

The width is 5, and the height is 3, so we know $w = 5$ and $h = 3$:

$$\text{Area} = 5 \times 3 = 15$$

Surface Area is the area of all faces added together.

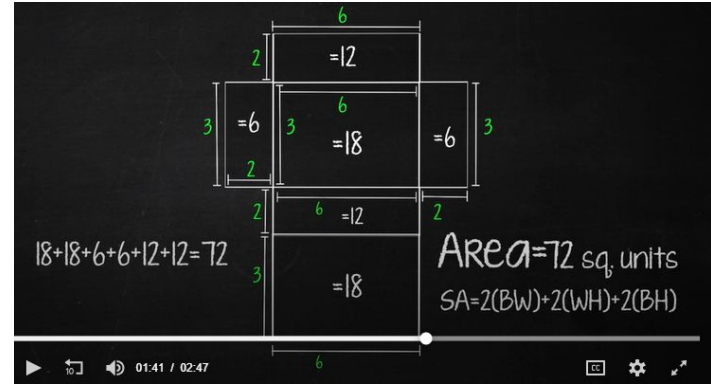

$18+18+6+6+12+12=72$

$\text{Area} = 72 \text{ sq. units}$

$SA = 2(BW) + 2(WH) + 2(BH)$

Net is a 3-dimensional shape unfolded and laid flat. (Click the link above to see 3D shapes fold and unfold into nets.)

[Nets](#) - Practice

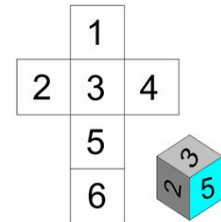

Practice:

Find the surface area of the cube and rectangular prism.

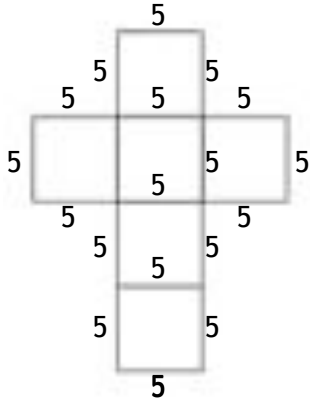
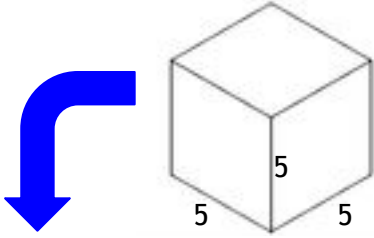

$$\begin{aligned} 5 \times 5 &= 25 \\ 5 \times 5 &= 25 \\ 5 \times 5 &= 25 \\ 5 \times 5 &= 25 \\ 5 \times 5 &= 25 \\ 5 \times 5 &= + 25 \\ \hline &150 \end{aligned}$$

Correct Answer

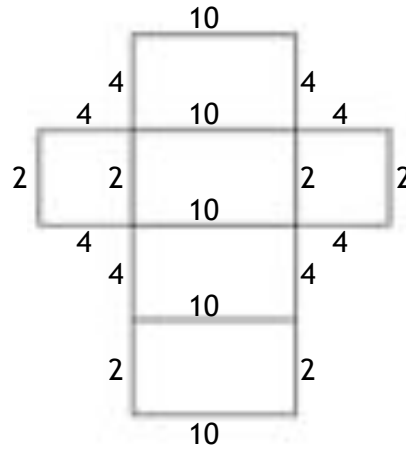
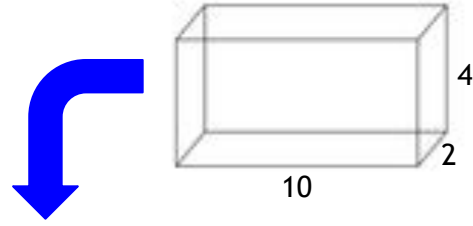

$$\begin{aligned} 10 \times 4 &= 40 \\ 10 \times 4 &= 40 \\ 10 \times 2 &= 20 \\ 10 \times 2 &= 20 \\ 4 \times 2 &= 8 \\ 4 \times 2 &= + 8 \\ \hline &136 \end{aligned}$$

Correct Answer

Practice: Go to this website:
[Surface Area of Cubes and Rectangular Prisms](#)

1. Look at the question carefully.
2. Make sure to have pencil and paper ready.
3. Solve the problem.
4. Type in the answer and then click “Answer”.

What is the surface area?

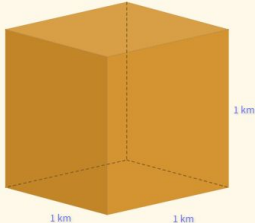

square km

Answer

Level 1 of 1

☆☆☆☆☆

Practice:

Answer the questions on a piece of paper.

Find the surface area of the following cubes and rectangular prisms.

1.

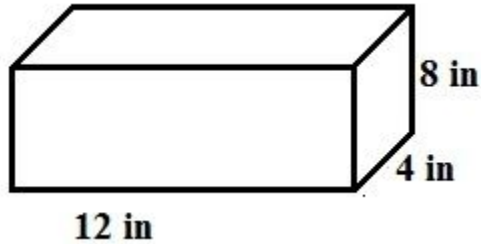

2.

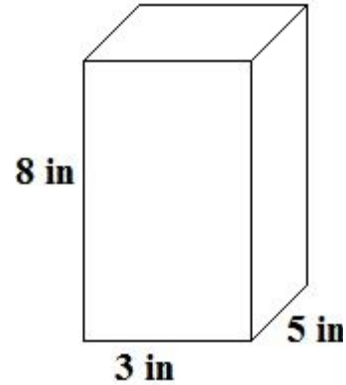

3.

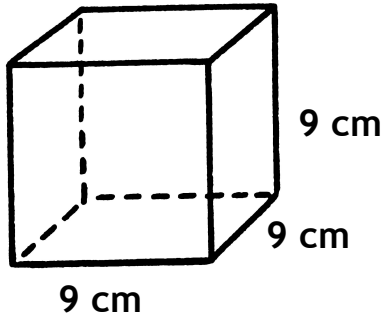

4.

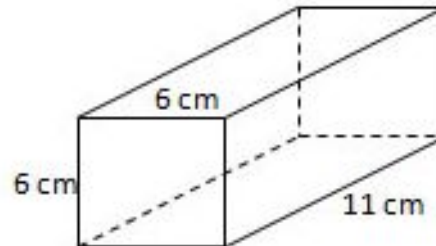

Answer Key:

Once you have completed the problems, check your answers here.

1.

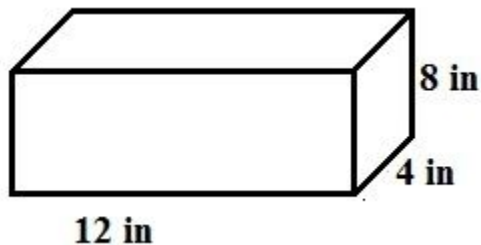

$$12 \times 4 = 48$$

$$12 \times 4 = 48$$

$$12 \times 8 = 96$$

$$12 \times 8 = 96$$

$$4 \times 8 = 32$$

$$4 \times 8 = \underline{+32}$$

$$352 \text{ in}^2$$

Correct Answer

2.

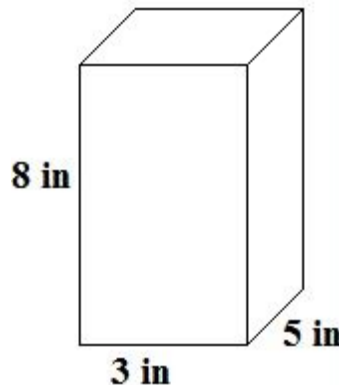

$$8 \times 5 = 40$$

$$8 \times 5 = 40$$

$$8 \times 3 = 24$$

$$8 \times 3 = 24$$

$$3 \times 5 = 15$$

$$3 \times 5 = \underline{+15}$$

$$158 \text{ in}^2$$

Correct Answer

Answer Key:

Once you have completed the problems, check your answers here.

3.

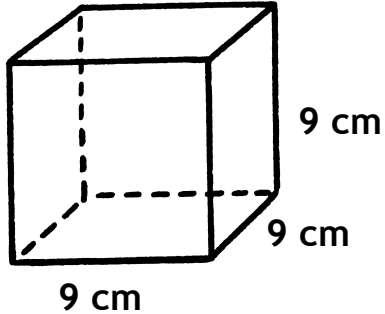

$$\begin{array}{r} 9 \times 9 = 81 \\ 9 \times 9 = 81 \\ 9 \times 9 = 81 \\ 9 \times 9 = 81 \\ 9 \times 9 = 81 \\ 9 \times 9 = 81 \\ \hline 9 \times 9 = +81 \end{array}$$

486 cm^2 ← Correct Answer

4.

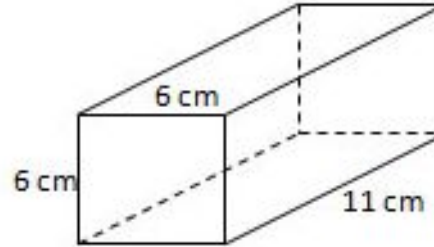

$$\begin{array}{r} 11 \times 6 = 66 \\ 11 \times 6 = 66 \\ 11 \times 6 = 66 \\ 11 \times 6 = 66 \\ 6 \times 6 = 36 \\ 6 \times 6 = 36 \\ \hline 6 \times 6 = +36 \end{array}$$

336 cm^2 ← Correct Answer

Additional Practice:

Click on the links below to get additional practice and to check your understanding!

[IXL](#) - Practice

[Quizizz](#) - Practice

[Open Middle](#) - Challenge 1

[Open Middle](#) - Challenge 2

[Open Middle](#) - Challenge 3

Additional Practice: Challenge

Find the surface area of the following figures.

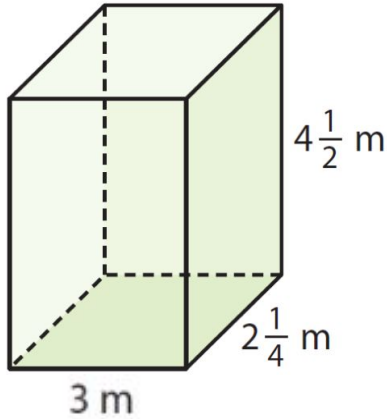

Find the surface area?

Jason knows that a figure has a surface area of 40 squared cm. The net below has 5 cm and 2 cm edges. Could the net below represent the figure? If not, what would you need to change?

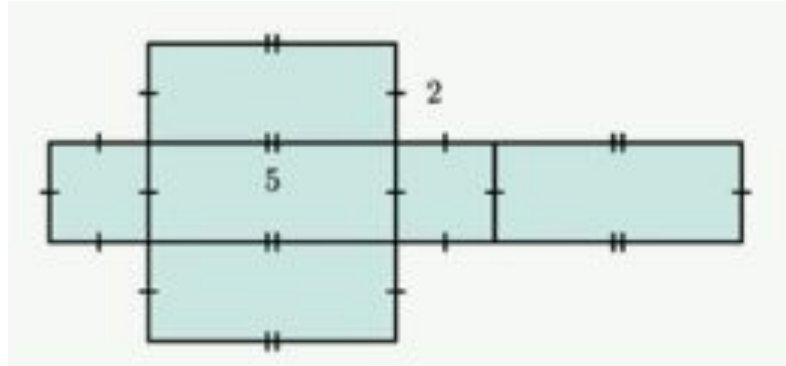

Additional Practice: Challenge Answers

Find the surface area of the following figures.

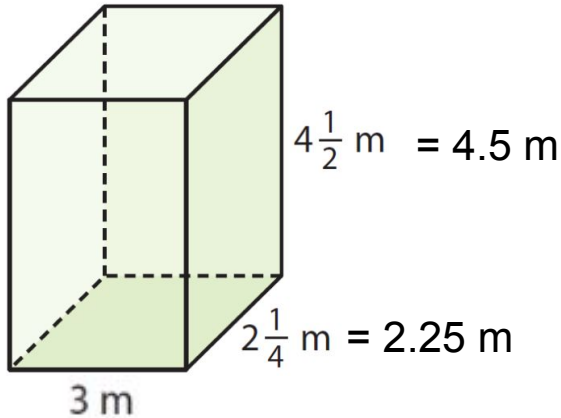

Find the surface area?

$$3.0 \times 2.25 = 6.75$$

$$3.0 \times 2.25 = 6.75$$

$$4.5 \times 2.25 = 10.125$$

$$4.5 \times 2.25 = 10.125$$

$$3.0 \times 4.5 = 13.50$$

$$3.0 \times 4.5 = +13.50$$

$$\hline 60.75\text{ cm}^2$$

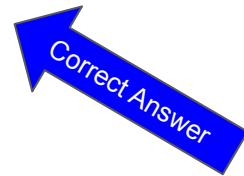

Additional Practice: Challenge Answers

Find the surface area of the following figures.

Jason knows that a figure has a surface area of 40 squared cm. The net below has 5 cm and 2 cm edges. Could the net below represent the figure? If not, what would you need to change?

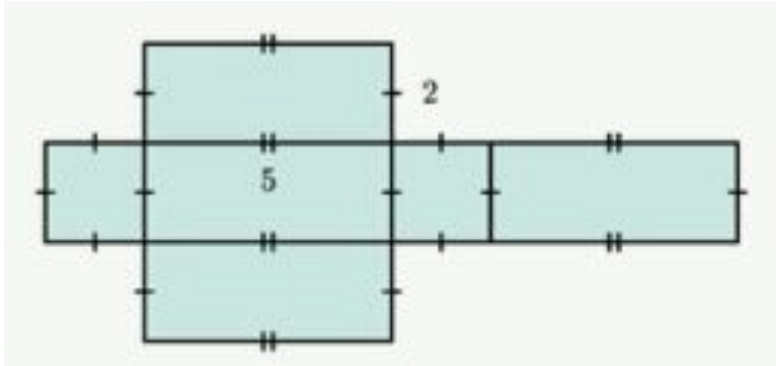

$$5 \times 2 = 10$$

$$5 \times 2 = 10$$

$$5 \times 2 = 10$$

$$5 \times 2 = 10$$

$$2 \times 2 = 4$$

$$2 \times 2 = \underline{+ 4}$$

$$48 \text{ cm}^2$$

$$4 \times 2 = 8$$

$$4 \times 2 = 8$$

$$4 \times 2 = 8$$

$$4 \times 2 = 8$$

$$2 \times 2 = 4$$

$$2 \times 2 = \underline{+ 4}$$

$$40 \text{ cm}^2$$

In order for the figure to equal 40 squared cm, you would need to change the measure of 5 cm to 4 cm.