



Industrial Technology Virtual Learning

**9-12/Advanced Metals/ Blue Print Reading
(Definitions of Lines)**

April 20, 2020



Blue Print Reading(Definition of Lines):April 20, 2020

Objective/Learning Target:

Students will read the following PPT to understand Definition of Lines. Following the PPT information covering Definition of Lines students will test their knowledge by answering Three questions.

Bell Ringer

The following is an example of a Working Drawing. There are Nine common types of lines used in design.

List as many of the different lines that you can find in this drawing.

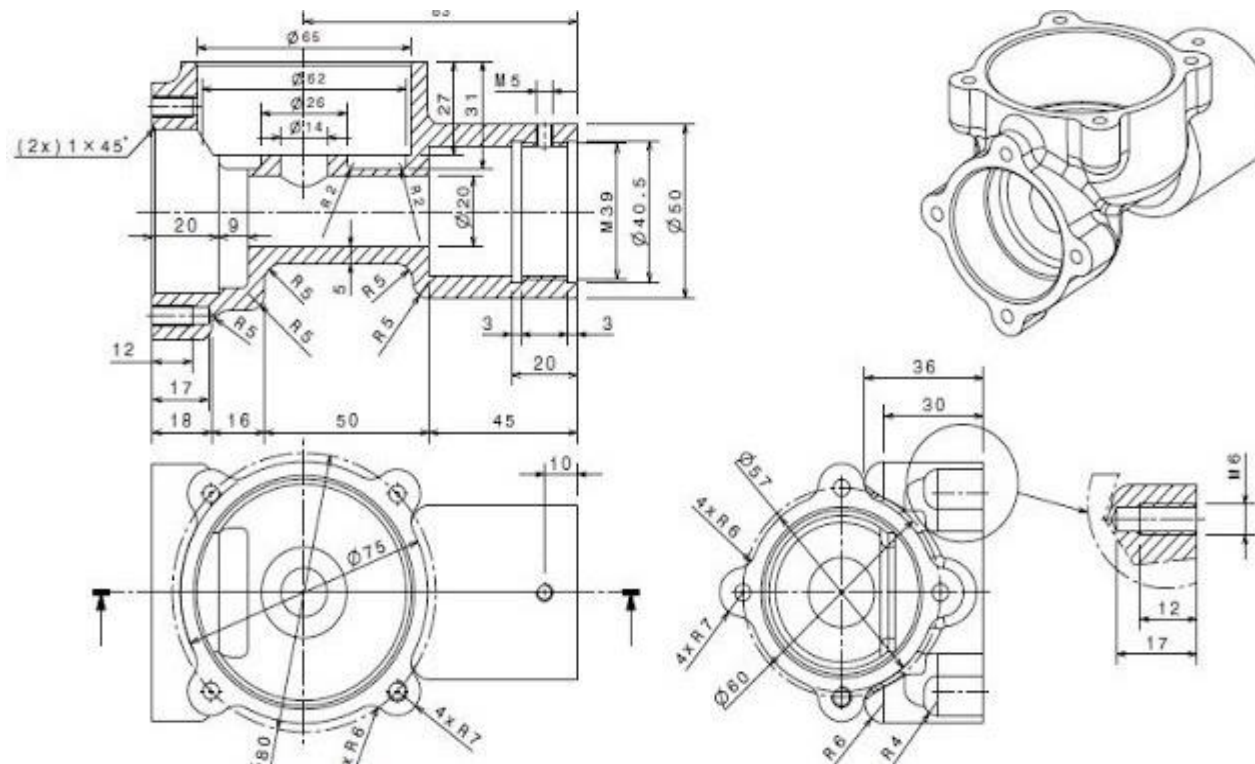

The Definition of Lines

In a typical drawing there are nine types of lines commonly used. Each has a particular meaning to the engineer, and a skilled worker must recognize and understand the meaning of the lines to correctly interpret the print.

1. **Visible Line**: the visible line is a thick continuous line that represents all edges and surfaces of an object that are visible in that view

2. **Hidden Line**: hidden lines have short dashes, and are used to show edges, surfaces and corners not visible in a particular view.

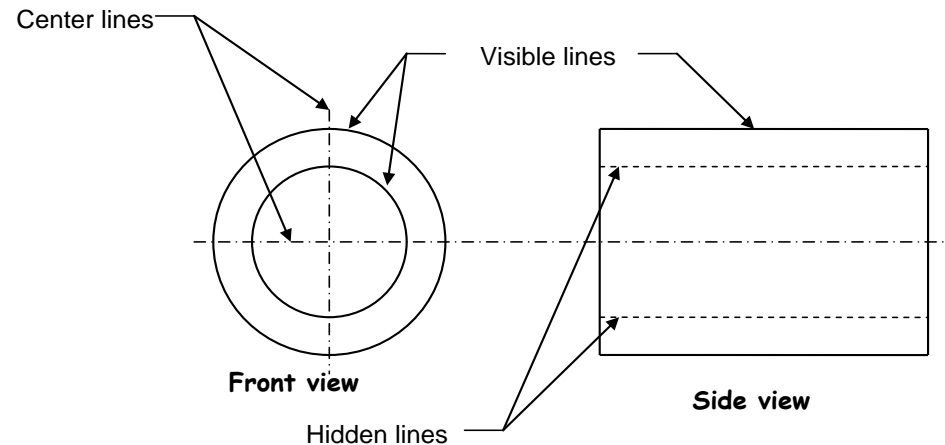

3. **Center Line**: center lines are a thin line with one short dash between two long dashes. They are used to show the centers of holes, arcs, and symmetrical parts (symmetrical means both sides are identical). Sometimes you will see the symbol CL, to designate a centerline, and SYM to tell you the part is symmetrical around the centerline.

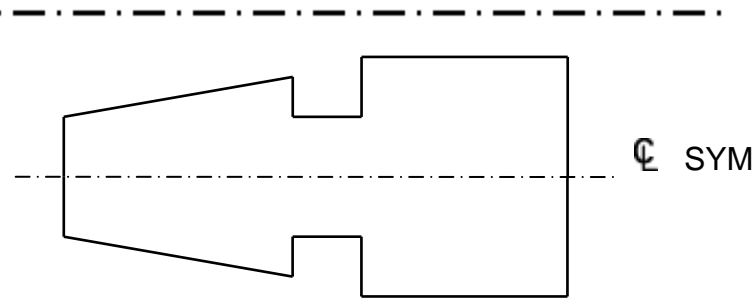

4. **Dimension Line**: dimension lines are thin lines that have arrows on both ends, and a dimension, or measurement, in between.

5. **Extension Line**: an extension line is a thin line, used to place a dimension away from the part, to make it easier to read

6. **Leader Line**: leaders are thin lines with one arrow that point to an area, and give specific information about that area.

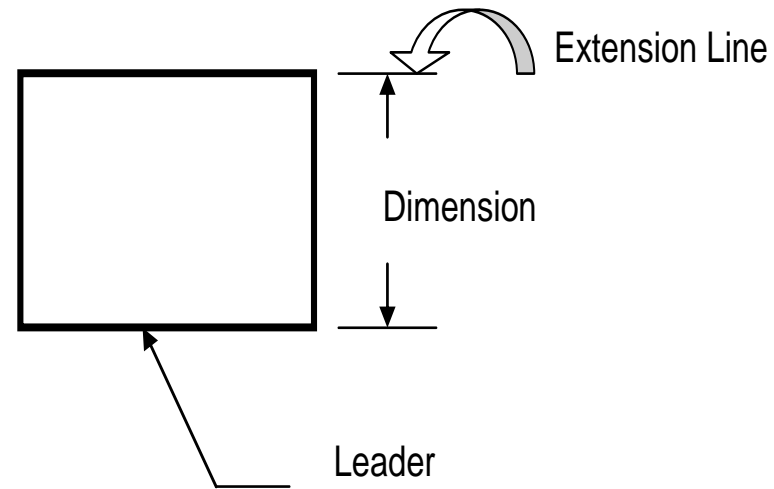

7. Cutting Plane lines/Section View lines: the cutting plane is a thick line, often with a 90° bend, that ends with an arrow. They are used in pairs, when we need to “cut” a part open to see more detail. The arrows indicate the direction your eyes are looking.

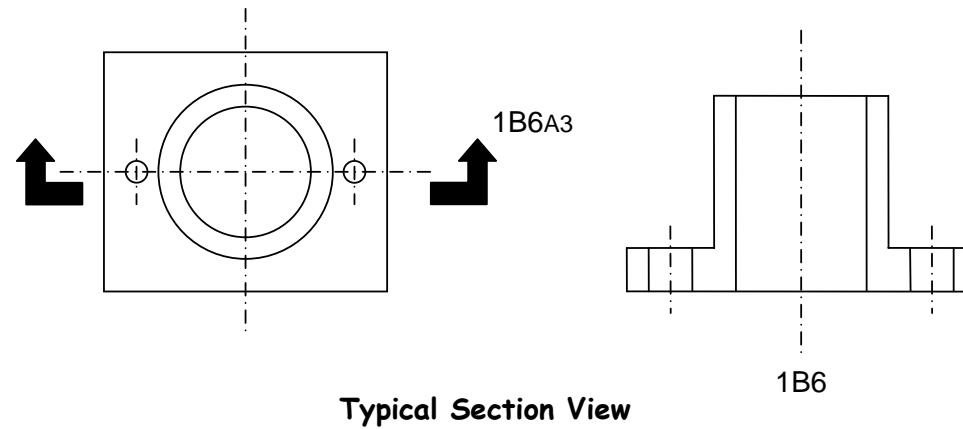
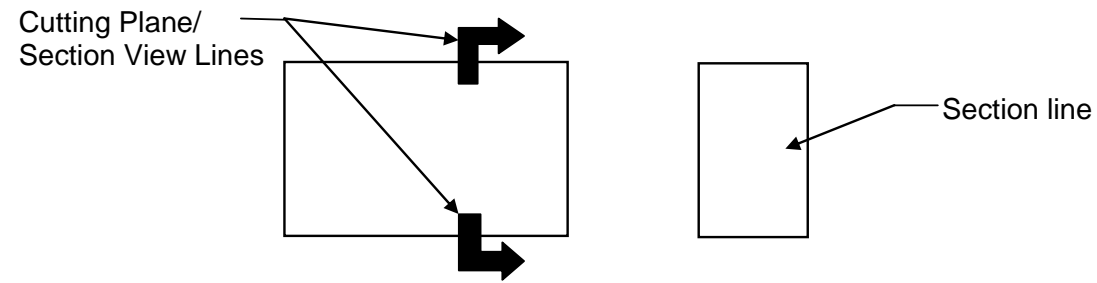

8. **Reference Line**: a thin line with two dashes. Reference lines are used to show alternate position, adjacent parts, or repeated detail.

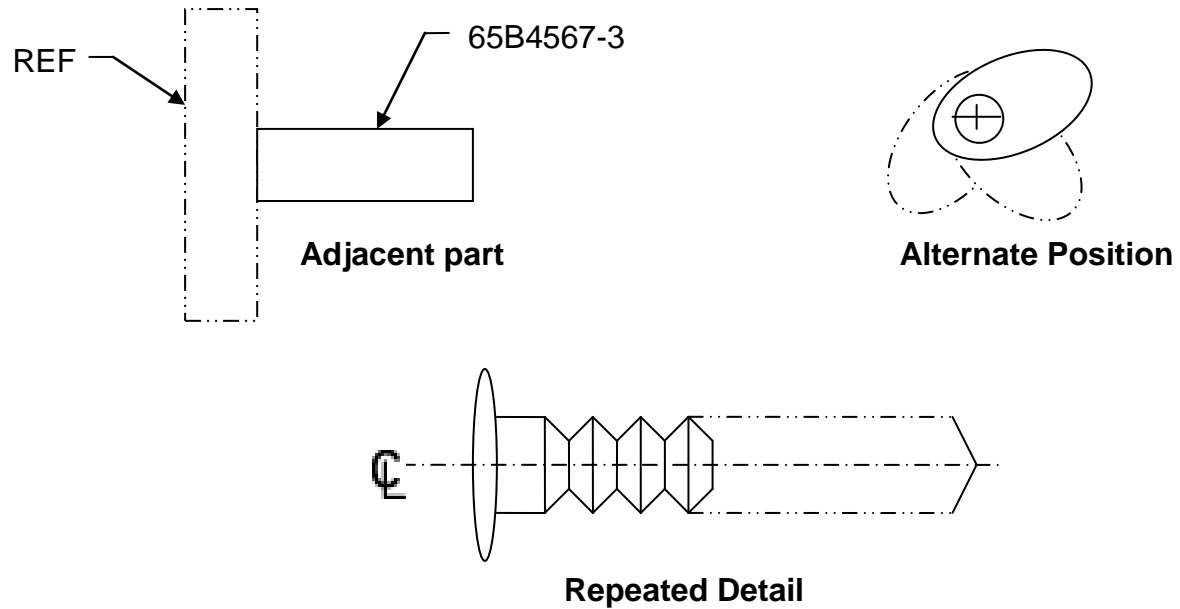

9. **Break Lines**: break lines are used to show that there is more to the part than is being shown. Some break lines are wavy lines, some are angular lines.

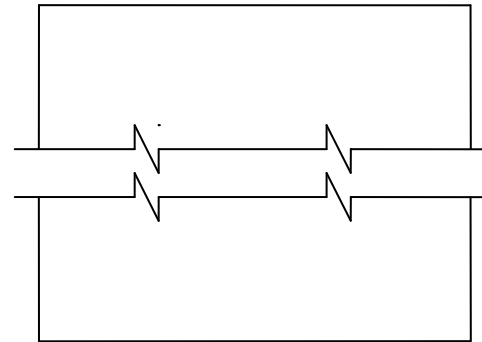
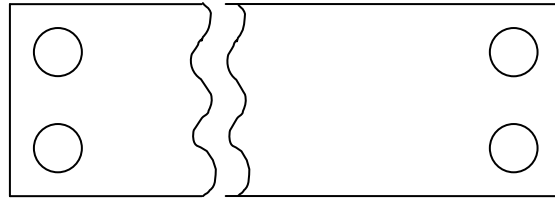

References

- <https://www.construct-ed.com/beginners-guide-how-to-read-construction-plans/>
- <https://www.letsbuild.com/blog/blueprints>
- <https://craftjack.com/toolbox/how-to-read-blueprints/>

Blueprint Reading Quiz

Question #One

1. List the Nine most common types of lines.

- A. _____
- B. _____
- C. _____
- D. _____
- E. _____
- F. _____
- G. _____
- H. _____
- I. _____

Answer

Visible Line

Hidden Line

Center Line

Dimension Line

Extension Line

Cutting Plane Line

Reference Line

Break Line

Question #Two. Name the types of lines shown below.
Check your own answers.

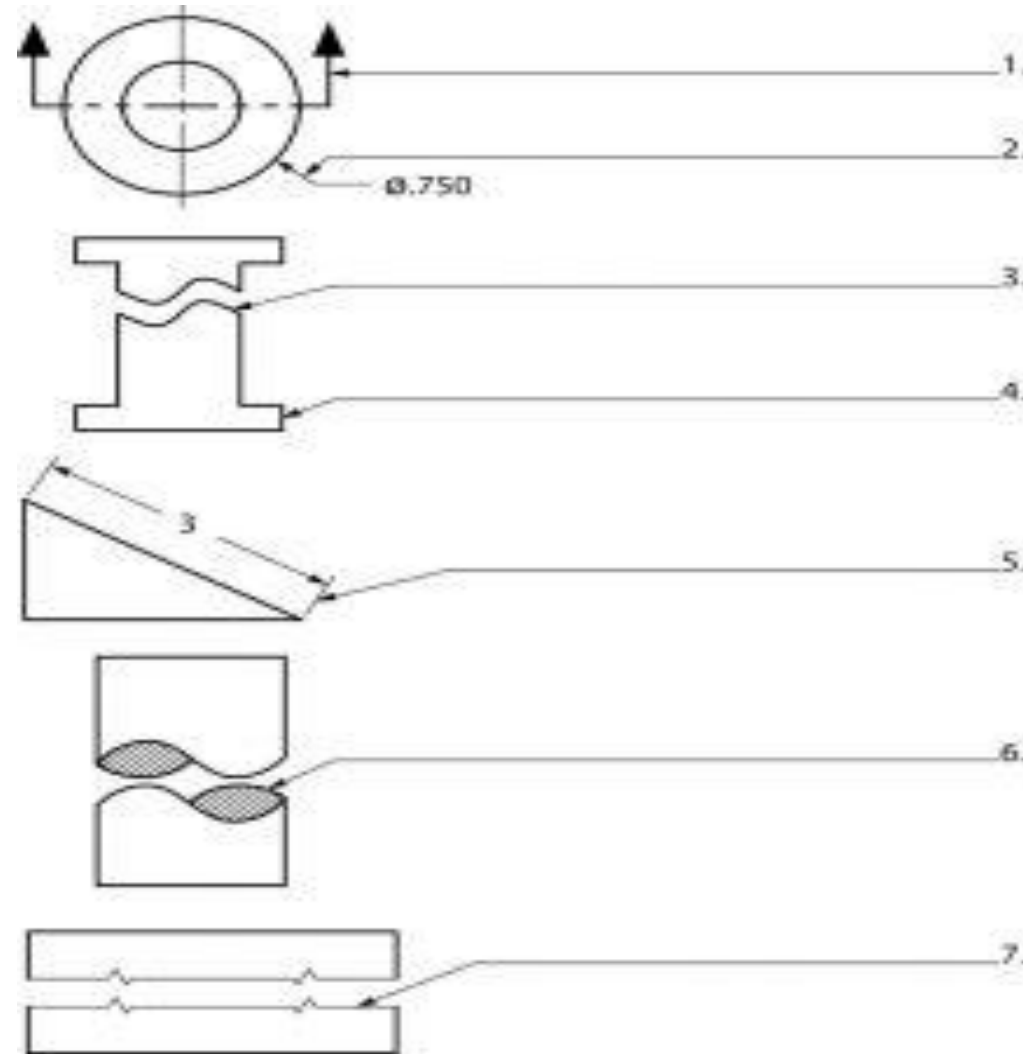

Question #Three. Draw and identify the lines needed to complete the figures as indicated. Check your own answers.

