



Industrial Technology Virtual Learning

CTE

May 11th, 2020



Machine Technology 2

Mechanical Fasteners

May 11th, 2020

Objective: Students will identify different types of mechanical fasteners and their proper application.

Metal Fasteners

Fasteners

- *Metal assemblies are often held together with fasteners, hardware devices that mechanically join or affix two or more objects together.*
- *Assembling with most types of fasteners allows components to be repeatedly assembled and disassembled.*
- *This is important where a product is expected to undergo modifications, repairs, or where it may provide access into an assembly.*



Bolts

- *Threaded shafts that use a threaded nut to fasten metal together.*
- *Bolts are sized by length and thread.*
- *Bolts are stronger than screws.*
- *Bolts are classified by the type of head.*
 - *Stove bolts and machine screws (actually bolts) are turned with a screwdriver.*
 - *Hexagonal- and square-head bolts are held in place with a wrench while the nut is turned to tighten.*

Fig. 25-1 Measurements of bolts and screws.

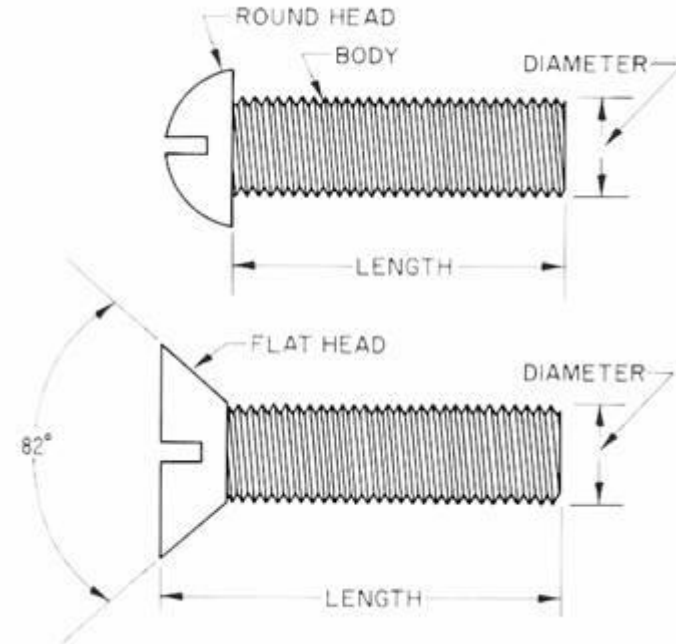

Types of Bolts

- *Carriage bolt*
 - *Smooth round head & coarse thread that starts part way down the shaft.*
 - *Usually used to attach a wooden part to metal.*
- *Machine bolt*
 - *Hexagonal head & only partially threaded.*
 - *Used for precision attachment using threads to secure materials together.*
- *Tap bolt*
 - *Similar to a machine bolt but the whole body is threaded.*
- *Stove bolt*
 - *Round or flat head with coarse thread along the whole body.*
 - *General purpose fastener used when precision fit is not necessary.*
- *Stud bolt*
 - *No head and threaded on both ends.*
 - *One end is driven into material & the other end is left exposed so that other parts can be fastened to it.*

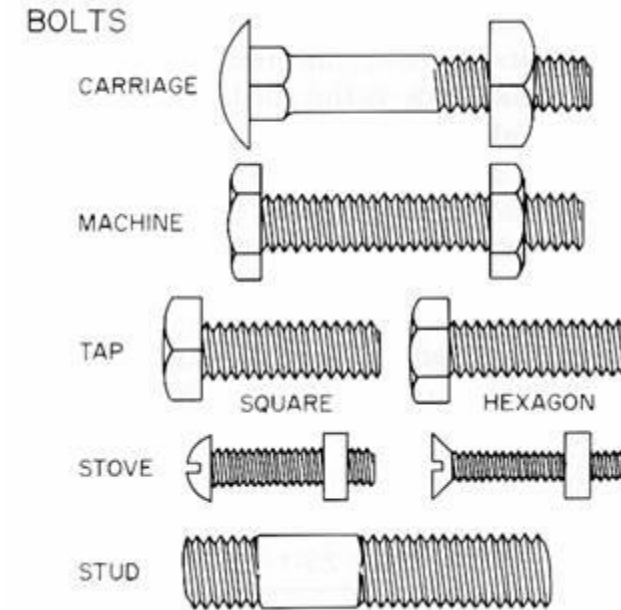

Types of Machine Screws

- *Machine & cap screws*
 - *Come with a variety of head & thread types.*
 - *Used for precision fit into thread holes in metal.*
- *Setscrew*
 - *Made with square heads or no heads.*
 - *Typically used for safety reasons to hold a sleeve, collar or gear on a shaft to prevent relative motion.*
- *Thumbscrews*
 - *Has one or two wings or a knurled head.*
 - *Used where a screw must be turned by hand using the thumb and a finger.*

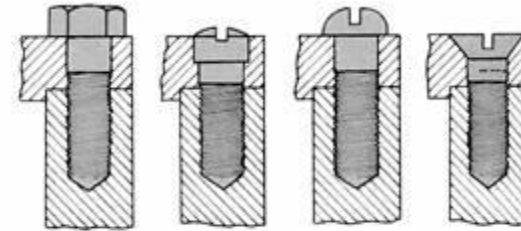

Fig. 25-4 Cap screw heads. Note the different positions.

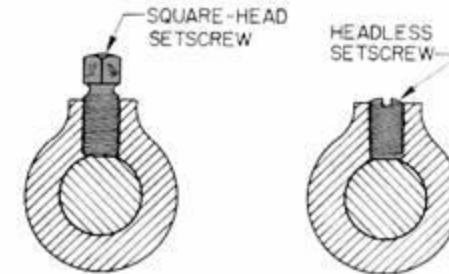

Fig. 25-5 Headed and headless set screws.



Sheet Metal Screws

- *Short thick screws that are self-threading (cut or form their own threads as driven into soft metals).*
- *Used in the economical assembly of sheet metal.*
- *Threaded all the way down the shank.*
- *Come in a variety of head types depending on application.*



Fig. 25-22 Thread-forming screws.



Fig. 25-23 Thread-cutting screws.

Lag Screw

- *Bolt is a bolt head with a screw body.*
- *Has either a square or hexagonal head.*
- *Used in fastening where maximum holding power is needed (i.e.- holding a vice to to a workbench).*

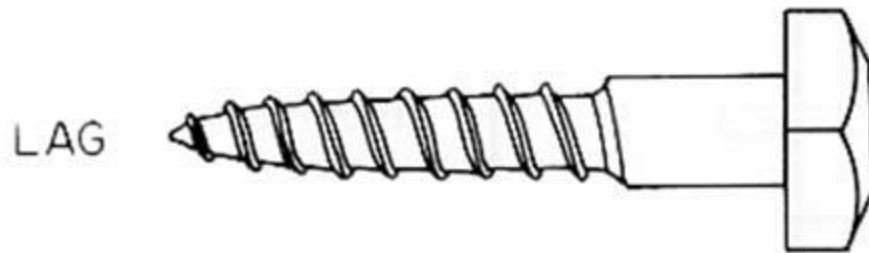

Bolts, screws detailed video

<https://www.youtube.com/watch?v=Lz2dRA7hjlQ>

Nuts

- *Type of hardware fastener with a threaded hole.*
- *Usually hexagonal to permit tightening with a wrench but may also be square, knurled, winged or otherwise shaped.*
- *Along with a bolt, nuts are designed to capture and fasten objects together.*

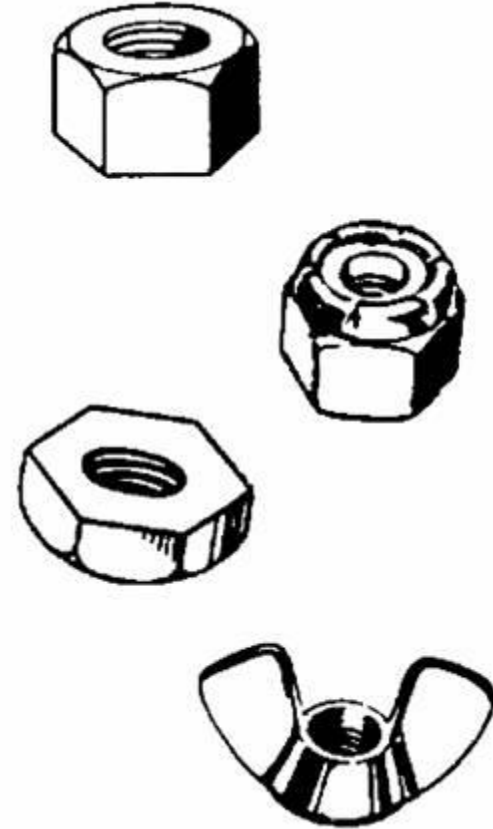

Type of Nuts

- *Machine screw nut (Hex nut)*
 - *Square or hexagonal shaped with fine or coarse thread.*
- *Jam nut (Lock nut)*
 - *Thinner than an ordinary nut.*
 - *Used as a lock to keep another nut from loosening.*
- *Castle nut*
 - *Has slots cut into the top of the nut that extend upward making it look like a castle.*
 - *A hex nut with a slightly reduced slotted cylindrical section on one end.*
 - *Used with a cotter pin to prevent loosening.*
- *Wing nut*
 - *A nut with two thin flat wings.*
 - *Used in place of a regular nut and can be turned with the thumb and forefinger.*

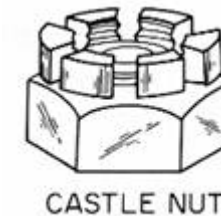

Types of nuts video

<https://www.youtube.com/watch?v=dV7vkljFCIA>

Washers

- *Placed under the bolt head or the nut for a firmer fasten.*
- *Designed to protect the surface under a bolt or nut.*
- *Used to spread load of a mechanical connection out over a greater area.*

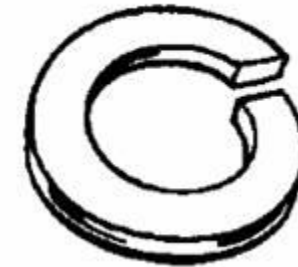
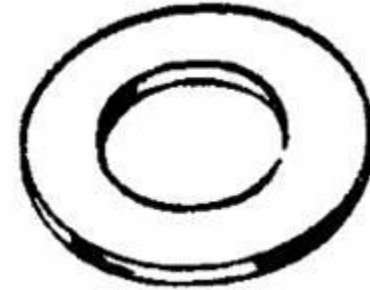

Type of Washers

– Plain washers

- *Circular, small flat piece to widen the bearing surface of a bolt head or nut.*
- *Measured by the diameter of the bolt that fits into it.*

– Lock washer

- *Used to lock a nut or screw in place, prevent it from moving from vibrations.*
 - *Helical spring - looks like a coil from a spring that tightens when applied to prevent movement.*
 - *Toothed – has teeth that wedge into bearing surface when applied to prevent movement.*



Fig. 25-12 *The shape of a plain washer.*

Fig. 25-13 *The position of a helical spring type lock washer.*



Fig. 25-14 *Common tooth-type lock washers.*

Pins

- *Used to hold mechanical parts together or limit travel of moving parts.*
- *Cotter pin*
 - *Made of soft wire.*
 - *Placed through a hole in a bolt behind a castle nut to prevent the nut from turning.*
- *Tapered pin*
 - *Used to hold a collar or pulley against a shaft.*
- *Roll pins*
 - *Made from sheet steel that is rolled into a tube.*
 - *Driven into holes slightly larger than a standard hole size so they grip tightly when pounded in.*

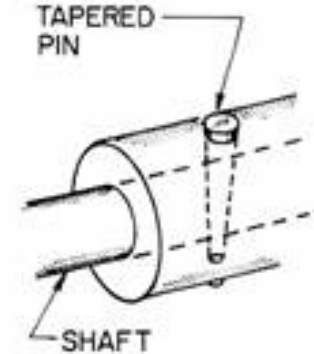
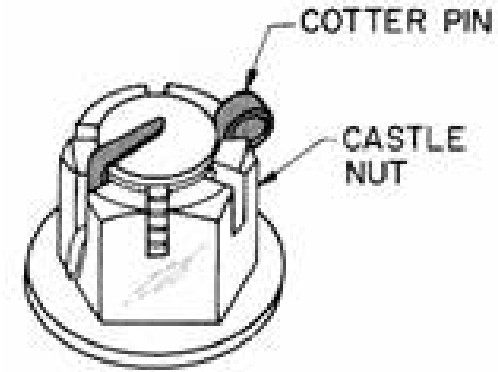
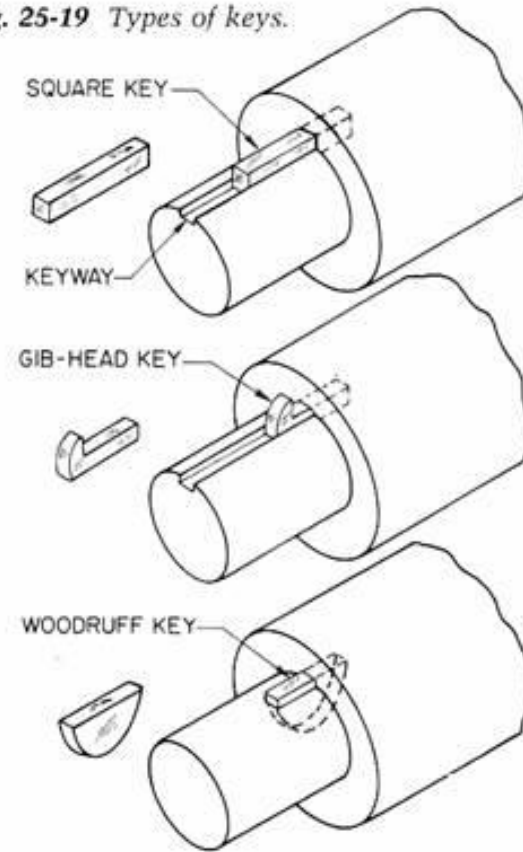

Fig. 25-18 An assortment of roll pins.

Keys

- Used to keep pulleys and gears from moving on shafts.
- Half the key fits into the keyway (a slot on the shaft), the other half fits into a slot that is on the pulley or gear.
- Square key
 - Most commonly used.
- Gib-head key
 - Toothed key that is useful when you need to remove the key from one side of the pulley or gear.
 - Can be removed with a wedge.
- Woodruff key
 - Semicircular in shape and fits a matching semicircular pocket in the shaft.
 - Key becomes locked in position and cannot be knocked loose due to vibration.

Fig. 25-19 Types of keys.



Review Questions

1. what type of bolt has coarse thread that starts part way down the shaft?
1. What is a machine bolt?
1. What is the difference between a machine bolt and a tap bolt?
1. according to the video over bolts, what is the term for a bolt with an circular ring on the head end?
1. what type of nut is designed to be tightened with the thumb and forefinger?